

Faster Fastener Removal



e-drill™

**Remove hard metal fasteners
in seconds not minutes.**

 **Perfect Point**

China Sales / Customer Service Center

GrandPac Aviation (Shanghai) Co., Ltd.
10/F, 777 West YanAn Road, Shanghai 20050 China
Tel: 86-21-6226 7999 Fax: 86-21-6226 6255

GRAND PACIFIC

E-mail: sales.cn@grand-pacific.com
Web site: www.grand-pacific.com
www.grand-pacific.cn

TECHNOLOGY

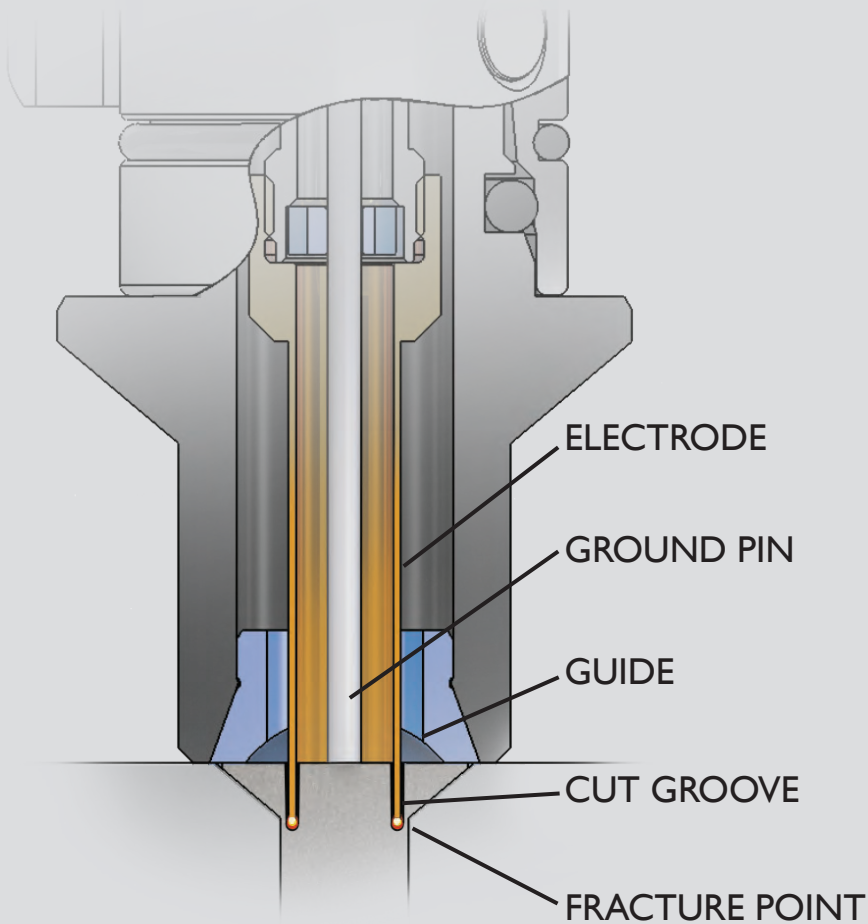

Perfect Point's patented handheld electro discharge machining (EDM) technology removes the hardest fasteners quickly and easily. The precision sized electrode cuts a circular groove of material from the fastener head leaving a very thin fracture point between the electrode and the airframe. The exact sizing of the electrode coupled with precision depth control greatly decreases the risk of airframe damage when compared to conventional removal methods. A closed-loop fluid system, consisting of filtered water, flushes the area and removes cut debris. Aggressive flushing during the cut means no heat is transferred to the surrounding area. The forceless cut process significantly reduces the risk of damage to the airframe and repetitive motion injury to the operator. Adaptable to flush head, protruding head and collar side applications. Reduced damage, fast cycle times, and elimination of debris result in efficiencies that mean a very quick return on investment.

PROCESS

A precision cut results in low punch out force, eliminating stress on the airframe structure. Drill shards are not created and all cut debris is captured, leaving only the severed fastener for cleanup.



- FORCELESS EDM CUTTING
- ERGONOMICALLY SUPERIOR
- QUICK CYCLE TIMES
- CLOSED LOOP SYSTEM
- CAPTURES CUT DEBRIS
- LOW PUNCH OUT FORCE
- REDUCES AIRFRAME DAMAGE
- WORKS ON ALL FASTENERS

BENEFITS

e•drill™ Fastener Removal Benefits:

Productivity Improvement - 5 to 10 times faster than mechanical drilling on hard metals (Titanium, Stainless Steel, Inconel, Monel).

Damage Reduction - 90%+ reduction in damage rate.

Ergonomics - the e•drill™ is a forceless process, while mechanical drilling exposes operators to all seven ergonomic risk factors (Force, Vibration, Compression, Posture, Repetition, Duration, and Noise).

FOD (Foreign Object Debris) - easier collection of FOD from the aircraft, faster cleanup of surrounding area, fewer injuries to operators. The only FOD produced by the e•drill™ is the fastener head and stem (no more drill shards).

Total Cost Reduction - the cost savings range is \$2.00 to \$5.00 per hard metal fastener removed (consumable and labor costs). Additional cost reduction comes from reduced damage, a more productive workforce, and less FOD to clean up after the job.

Remove All Fastener Types - Hi-Lok®, Jo-Bolt®, CherryLOCK®, CherryMAX®, HuckBolt®, Composi-Lok® & more.

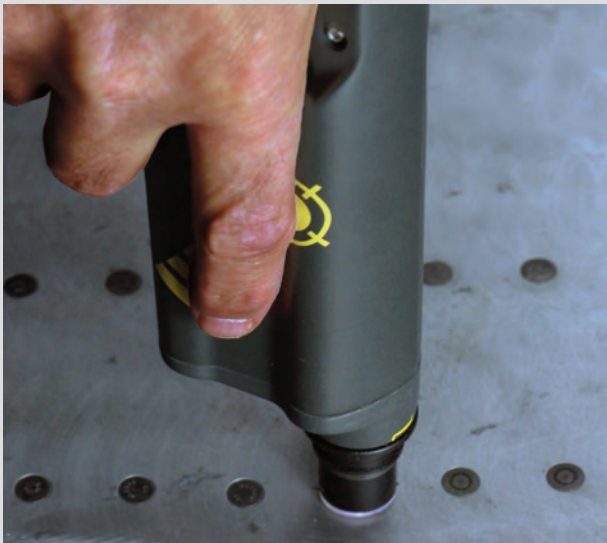

ACCESSORIES



VACUUM LOCATOR



GUIDED PUNCHES



ADAPTER KITS

Perfect Point offers a complete line of **e•drill™** accessories that will handle most fastener types and installations. Adapters are currently available for flush head and protruding head applications from 3/32" to 3/8". Collar side adapters are available from 5/32" to 1/4". The library of fastener types, sizes and materials is constantly expanding and Perfect Point's engineering staff can create custom solutions for many specific fastener removal needs. Precision optical locators and guided punches augment the **e•drill's™** labor savings and damage avoidance benefits.

SPECIFICATIONS

Fastener Removal:

Fastener pin diameter

3/32" to 3/8" (head side)

5/32" to 1/4" (collar side)

Flange removal time*

Aluminum 3 sec.

Titanium 10 sec.

Inconel 12 sec.

*Approx. based on 1/4" pin diameter

Material

Aluminum, Stainless, Titanium,

Inconel, etc.

Physical:

Mobile service unit

Dimensions: 19"W x 38"H x 16"D

Weight: 148 lbs.

Umbilical cable: 10' long

Hand Tool

Dimensions: 7.5"L x 5"H

Weight: 1.5 lbs.

Power

220-240v, Single Phase, 20 amp

All specifications subject to
change without notice.

US Patent No. 8,178,814 B2

©2012. Perfect Point Corporation.

e•drill™ proudly made in the USA

China Sales / Customer Service Center

GrandPac Aviation (Shanghai) Co., Ltd.
10/F, 777 West YanAn Road, Shanghai 20050 China
Tel: 86-21-6226 7999 Fax: 86-21-6226 6255

GRAND PACIFIC

E-mail: sales.cn@grand-pacific.com
Web site: www.grand-pacific.com
www.grand-pacific.cn

Coating Removal System



Free-standing and backpack system



Targeted blast with debris recovery

Perfect Point's patented S-Blaster technology removes coatings, fillers and corrosion from fasteners utilizing plastic blast media. Particulates are vacuumed back into the system, media is recycled, waste is extracted and clean air is expelled through an onboard cartridge HEPA filter.

 Perfect Point

s-blaster

中国销售 / 服务中心

美国GP公司/上海嘉沛特航空科技有限公司
地址：上海市延安西路777号10楼1001室
电话：86-21-62267999 传真：86-21-62266255

GRAND PACIFIC

E-mail: sales.cn@grand-pacific.com
Web site: www.grand-pacific.com
www.grand-pacific.cn

s•blaster

Coating Removal System

System Features

- Quickly removes coatings, fillers and corrosion from all fastener types.
- For threaded fasteners (Phillips, Torx, hex socket, etc.) material is removed from the head, clearing the tool recess, resulting in positive engagement for removal without damage to the fastener or surrounding area.
- For "permanent" fasteners, the S-Blaster is the ideal fastener preparation solution prior to removal with the E-Drill which requires a clean, conductive fastener head.
- Self-contained unit, requires no additional vacuum systems.
- Simple to use, the only requirement is 90 PSI of clean, dry, oil-free compressed air through a 1/4" air line.
- Plastic blast media is recycled and reused, lowering operational costs and improving the S-Blaster's environmental benefit. Automatically separates out damaged media and deposits into debris container for disposal.
- Exposure to debris is minimized by sealed disposal container and proprietary cartridge HEPA filtration system.
- May be used as a free-standing or backpack system - lightweight (20lbs.)
- Variable timer allows user to dial in proper settings for a particular coating/fastener, ensuring a clean fastener in the shortest time possible.



Type	Closed-loop vacuum spot-blasting system
Application	Surface coating removal from fastener heads
Debris collection	Resealable, disposable container
Height, width, depth	18" x 12" x 8"
Weight	20lbs
Hose length	4.5 ft
Capacity, media	0.25 gallons
Capacity, debris	0.12 gallons
Air consumption	3.0 CFM
Media type	Plastic blast media (20/30 urea)
Media recovery	Vacuum, cyclonic separation
User controls	Timed blast and vacuum, or vacuum only
Blast duration	Adjustable, 1 to 30 seconds
Filtration	Disposable HEPA with 100 PPI prefilter
Noise level	Less than 60db (estimated)



中国销售 / 服务中心

美国GP公司/上海嘉沛特航空科技有限公司
 地址：上海市延安西路777号10楼1001室
 电话：86-21-62267999 传真：86-21-62266255



E-mail: sales.cn@grand-pacific.com
 Web site: www.grand-pacific.com
 www.grand-pacific.cn